

SPECIFICATION

(產品規格書)

PART NO. : SMD 5730
DESCRIPTION : 0.5W 45LM 白光

■ Applications

(應用)

- ◆ General Lighting
(普通照明)
- ◆ Advertisement
(廣告燈)
- ◆ Architectural Lighting
(建筑照明)
- ◆ Street Lamps
(路燈)

■ Package Dimensions (外觀尺寸)

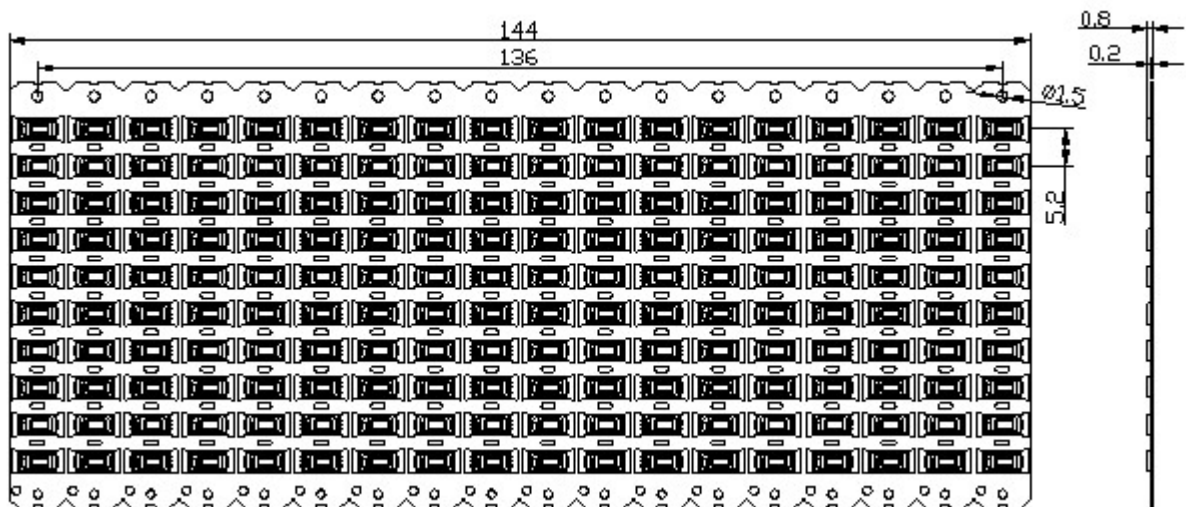
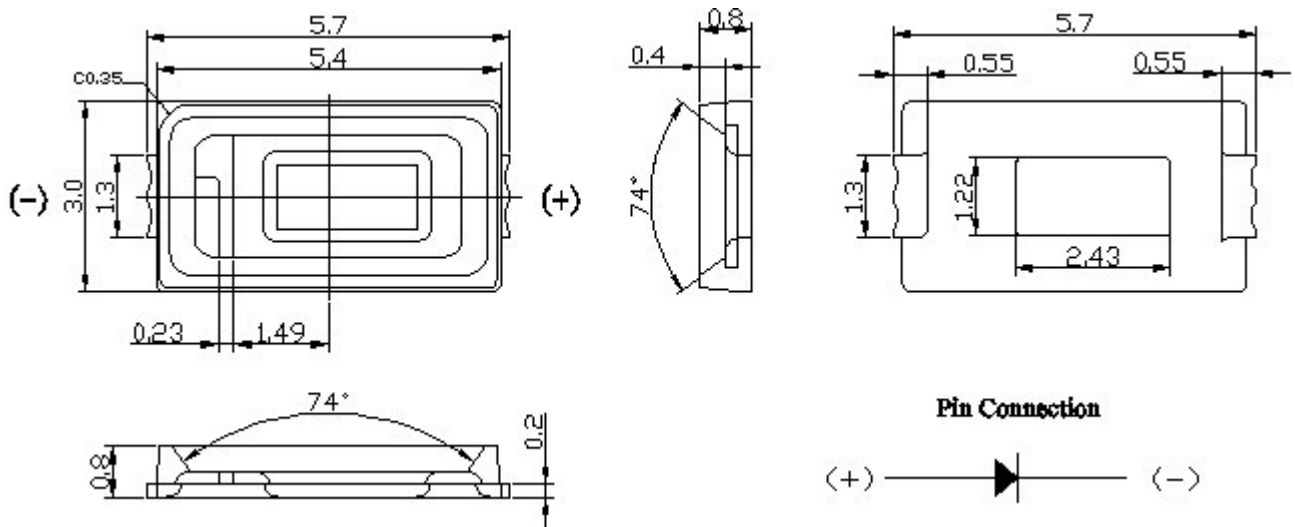

■ Electrical/Optical Characteristics (At T_A=25°C) (光電參數)

Parameter (參數)	Symbol (符號)	Conditions (測試條件)	Min. (最小值)	Avg. (平均值)	Max. (最大值)	Units (單位)
Luminous Flux (發光強度)	Φ	I _F =120mA	45	--	50	lm
Color Temperature (色溫)	CCT	I _F =120mA	6000	--	6500	K
Forward Voltage (正向壓降)	V _F	I _F =120mA	3.2	--	3.4	V
Thermal Resistance Junction To Board (熱阻)	RΘ _{J-B}	I _F =120mA	--	12	--	°C/W
Reverse Current (反響漏電流)	I _R	V _R =5V	--	1	--	μA
Viewing Angle ^[1] (發光角度)	2Θ _{1/2}	I _F =120mA	--	140	--	Deg

■ Absolute Maximum Rating(At T_A=25°C) (極限參數)

Parameter (參數)	Symbol (符號)	Ratings (數值)	Units (單位)
Power Dissipation (功率)	P _D	0.5	W
Continuous Forward Current (正向輸入電流)	I _F	120	mA
LED Junction Temperature (結點溫度)	T _J	150	°C
Reverse Voltage (反向電壓)	V _R	5	V
Operating Temperature Range (工作溫度)	T _{OPR}	-40°C To +85°C	
Storage Temperature Range (儲存溫度)	T _{STG}	-40°C To +100°C	
Manual Soldering Temperature (手工焊接溫度)	T _{SOL}	350°C± 20°C For 3 Seconds	
Soldering Temperature (回流焊接溫度)	T _{SOL}	260°C± 20°C For 5 Seconds	
ESD Sensitivity (抗靜電能力)	ESD	2000V HBM	

Unit : mm

General Tolerance : ± 0.05

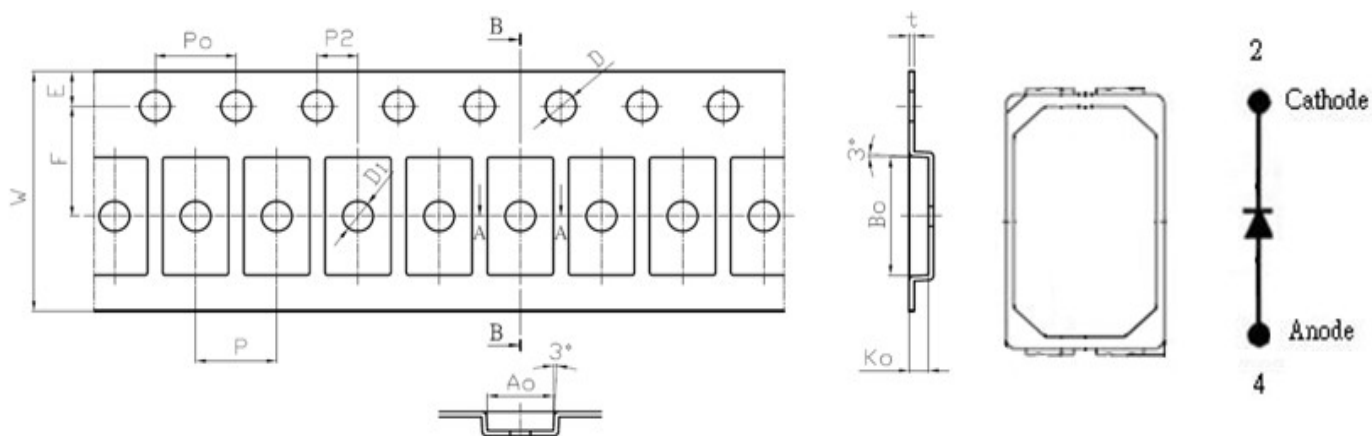
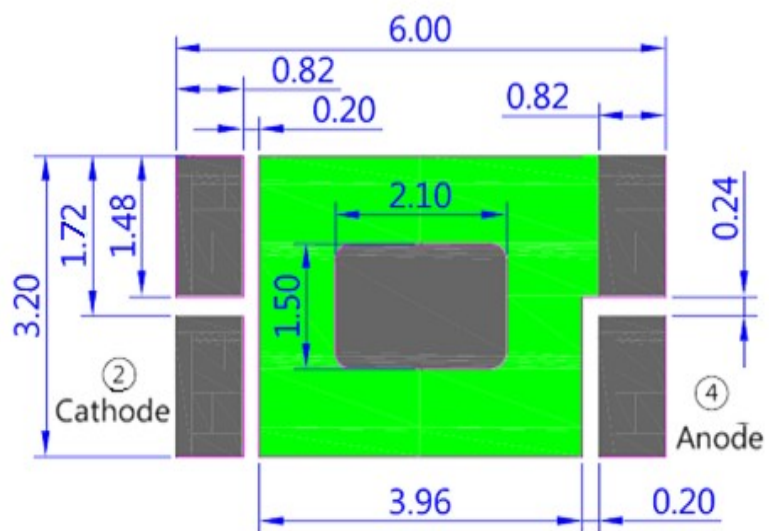

建議使用以下焊接模式進行回流焊接

Precautions For use

(1) Storage

In order to avoid absorption of moisture it is recommended that the products are stored in the dry box (or dessicator) with a dessicant. Alternatively the following environment is recommended:

Storage temperature :5°C~30°C Humidity:60% HR max.

(2) Any mechanical force or any excess vibration should be avoided during the cooling process after soldering.

(3) Components should not be mounted on distorted Printed Circuit Boards.

(4) Devices should not be used in any type of fluid such as water,oil,organic solvents etc.
When cleaning is required,IPA should be used.

(5) Devices should be soldered within 7 days after opening the moisture-proof packing.

(6) ESD Precautions.Static Electricity and surge damages LEDs.

It is recommended that wrist bands or anti-electrostatic gloves be used when handling the LEDs.All devices,equipment and machinery should be properly grounded.

(7) It is recommended to use individual resistors when LEDs are used in parallel circuits in order to improve performance.

使用說明

一、貯存：為避免吸潮建議將產品貯存在放有乾燥劑的乾燥櫃中，貯存溫度為：5°C~30°C，溼度：≤60%HR。

二、產品在焊錫后冷卻過程中避免機械壓力和過大震動。

三、禁止焊接在變形PCB板上。

四、產品不得接觸水、油、有機溶液。

五、打開防潮包裝后7天內產品使用完畢。

六、防靜電要求：使用產品時，必須戴防靜電環或防靜電手套，所有設備、裝置、機台必須有效接地。

七、將產品與電阻配合使用效果更佳