

## Glass Passivated Standard Recovery Diodes (Stud Version), 70A

### FEATURES

- Glass passivated chips
- High surge current capability
- Stud cathode and stud anode version
- Wide current range
- Voltage up to 1600V  $V_{RRM}$
- RoHS compliant

### TYPICAL APPLICATIONS

- Battery charges
- Converters
- Power supplies
- Machine tool controls
- Welder



DO-203AB(DO-5)

### PRODUCT SUMMARY

$I_{F(AV)}$	70A
-------------	-----

### MAJOR RATINGS AND CHARACTERISTICS

PARAMETER	TEST CONDITIONS	70D(R)		UNIT
		02 TO 12	16	
$I_{F(AV)}$	$T_C$	70	70	A
		140	110	°C
$I_{F(RMS)}$		110		A
$I_{FSM}$	50 HZ	1200		A
	60 HZ	1250		
$I^2t$	50 HZ	7200		A <sup>2</sup> s
	60 HZ	6540		
$V_{RRM}$	Range	200 to 1200	1600	V
$T_J$		-65 to 180	-65 to 150	°C

### ELECTRICAL SPECIFICATIONS

#### VOLTAGE RATINGS

TYPE NUMBER	VOLTAGE CODE	$V_{RRM}$ , MAXIMUM REPETITIVE PEAK REVERSE VOLTAGE V	$V_{RSM}$ , MAXIMUM NON-REPETITIVE PEAK VOLTAGE V	$V_{R(BR)}$ , MINIMUM AVALANCHE VOLTAGE V <sup>(1)</sup>	$V_{RRM}$ , MAXIMUM AT $T_J=175^\circ\text{C}$ mA
70D(R)	02	200	300	300	15
	04	400	500	500	
	06	600	720	725	
	08	800	960	950	9
	10	1000	1200	1150	
	12	1200	1440	1350	
	16	1600	1900	1750	
					4.5

FORWARD CONDUCTION						
PARAMETER	SYMBOL	TEST CONDITIONS		70D(R)		UNIT
				02 TO 12	16	
Maximum average forward current at case temperature	$I_{F(AV)}$	180° conduction, half sine wave		70	70	A
				140	110	°C
Maximum RMS forward current	$I_{F(RMS)}$			110		A
Maximum peak, one-cycle forward, non-repetitive surge current	$I_{FSM}$	t = 10ms	No voltage reappplied	1200		A
		t = 8.3ms	No voltage reappplied	1250		
		t = 10ms	100% $V_{RRM}$ reappplied	1000		
		t = 8.3ms	100% $V_{RRM}$ reappplied	1050		
Maximum $I^2t$ for fusing	$I^2t$	t = 10ms	No voltage reappplied	7200		A <sup>2</sup> s
		t = 8.3ms	No voltage reappplied	6540		
		t = 10ms	100% $V_{RRM}$ reappplied	5070		
		t = 8.3ms	100% $V_{RRM}$ reappplied	4610		
Maximum $I^2\sqrt{t}$ for fusing	$I^2\sqrt{t}$	t = 0.1 to 10 ms, no voltage reappplied		72000		A <sup>2</sup> √s
Maximum forward voltage drop	$V_{FM}$	$I_{pk} = 220A, T_J = 25^\circ C, t_p = 400\mu s$ rectangular wave		1.35	1.46	V

THERMAL AND MECHANICAL SPECIFICATIONS						
PARAMETER	SYMBOL	TEST CONDITIONS		70D(R)		UNIT
				02 TO 12	16	
Maximum junction operating and storage temperature range	$T_J, T_{stg}$			- 65 to 180	- 65 to 150	°C
Maximum thermal resistance, junction to case	$R_{thJC}$	DC operation		0.45		K/W
Maximum thermal resistance case to heatsink	$R_{thCS}$	Mounting surface, smooth, flat and greased		0.25		
Maximum allowable mounting torque (+0% , -10%)		Not lubricated thread ,tighting on nut <sup>(1)</sup>		3.4(30)		N · m (lbf · in)
		Lubricated thread ,tighting on nut <sup>(1)</sup>		2.3(20)		
		Not lubricated thread ,tighting on hexagon <sup>(2)</sup>		4.2(37)		N · m (lbf · in)
		Lubricated thread ,tighting on hexagon <sup>(2)</sup>		3.2(28)		
Approximate weight				15		g
				0.53		oz.
Case style		See dimensions - link at the end of datasheet		DO-203AB (DO-5)		

**Note**

(1) Recommended for pass-through holes.

(2) Recommended for holed threaded heatsinks.

$\Delta R_{thJC}$ CONDUCTION					
CONDUCTION ANGLE	SINUSOIDAL CONDUCTION	RECTANGULAR CONDUCTION	TEST CONDUCTIONS		UNITS
180°	0.08	0.06	$T_J = T_J$ maximum		K/W
120°	0.10	0.11			
90°	0.13	0.14			
60°	0.19	0.20			
30°	0.30	0.30			

**Note**

• The table above shows the increment of thermal resistance  $R_{thJC}$  when devices operate at different conduction angles than DC

**Fig.1 Current Ratings Characteristics**

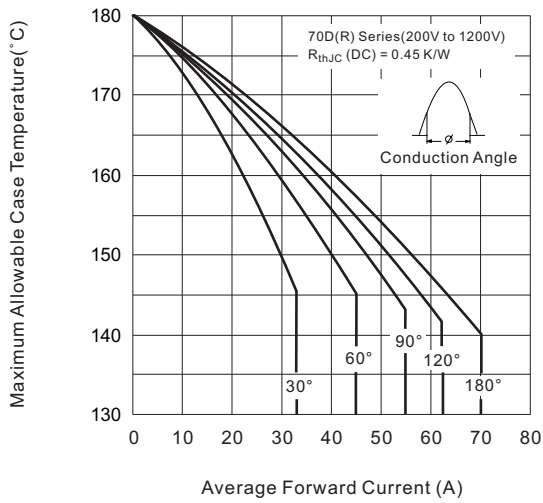

**Fig.2 Current Ratings Characteristics**

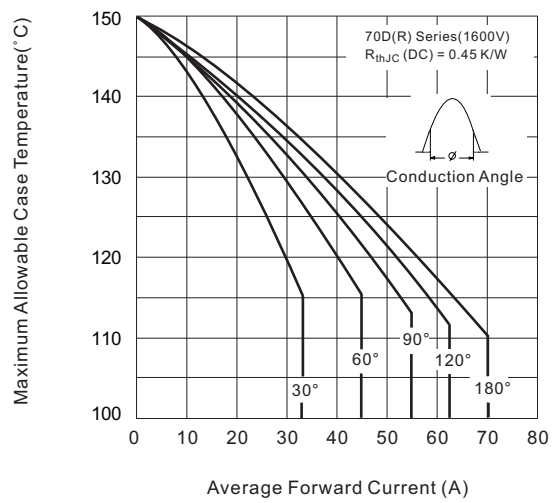

**Fig.3 Current Ratings Characteristics**

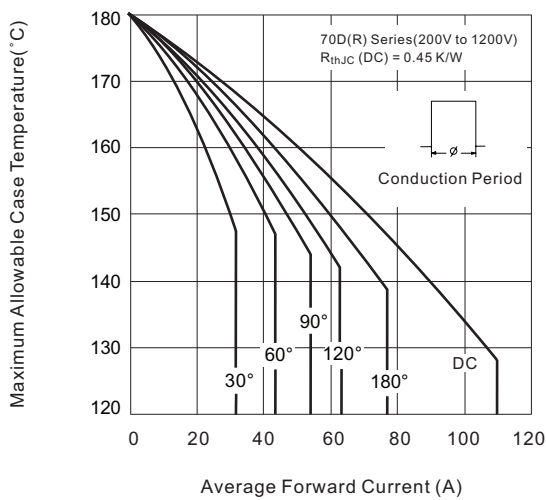

**Fig.4 Current Ratings Characteristics**

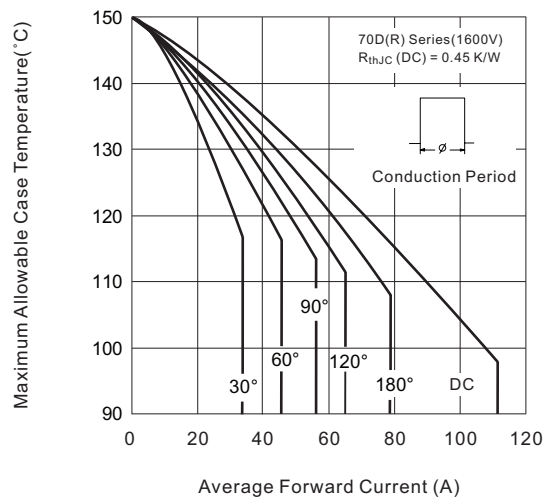

**Fig.5 Forward Power Loss Characteristics**

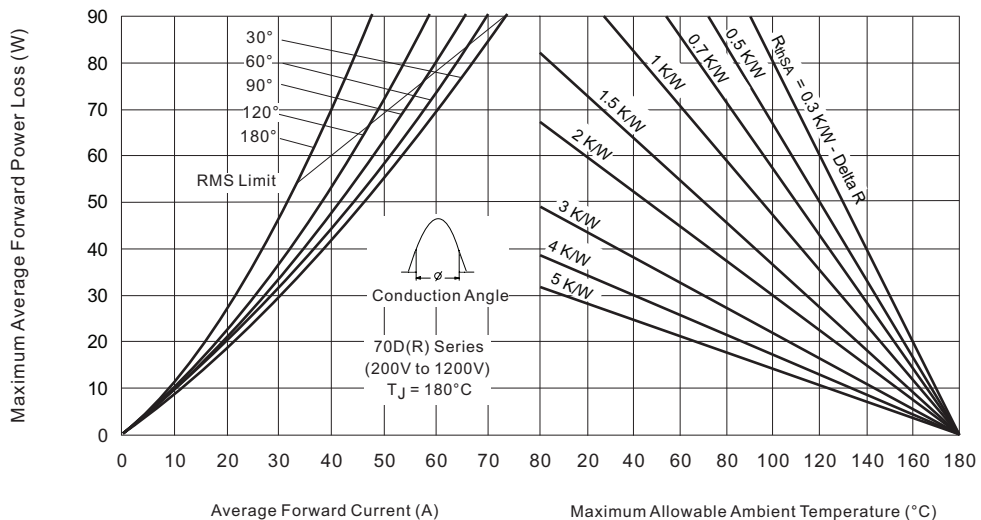

**Fig.6 Forward Power Loss Characteristics**

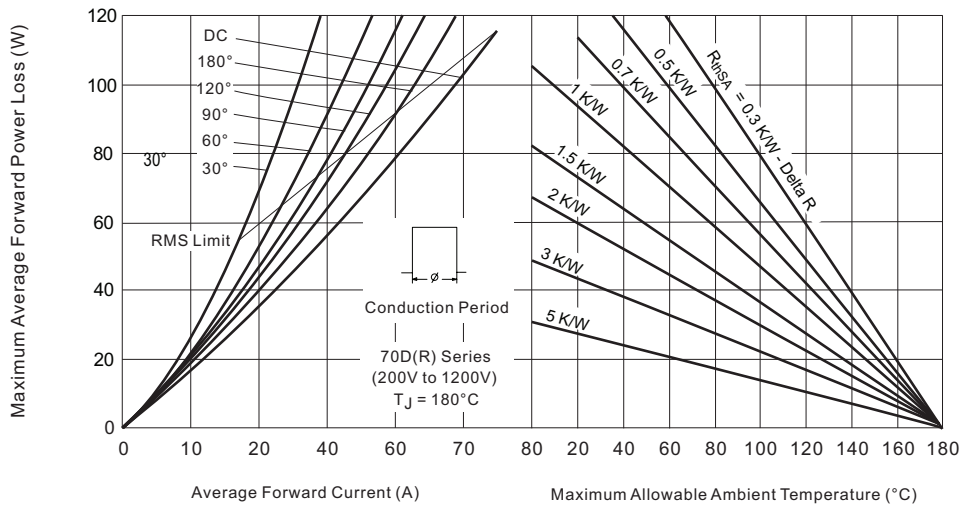

**Fig.7 Forward Power Loss Characteristics**

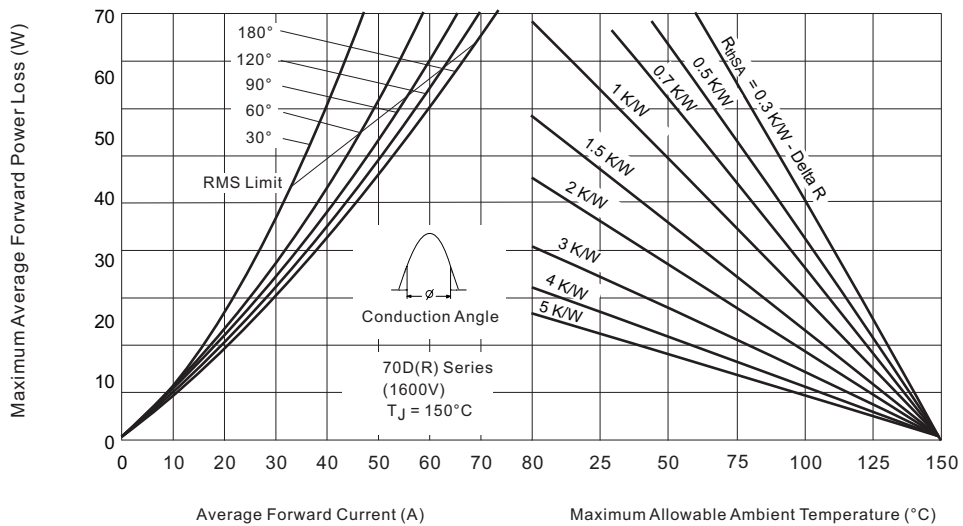

**Fig.8 Forward Power Loss Characteristics**

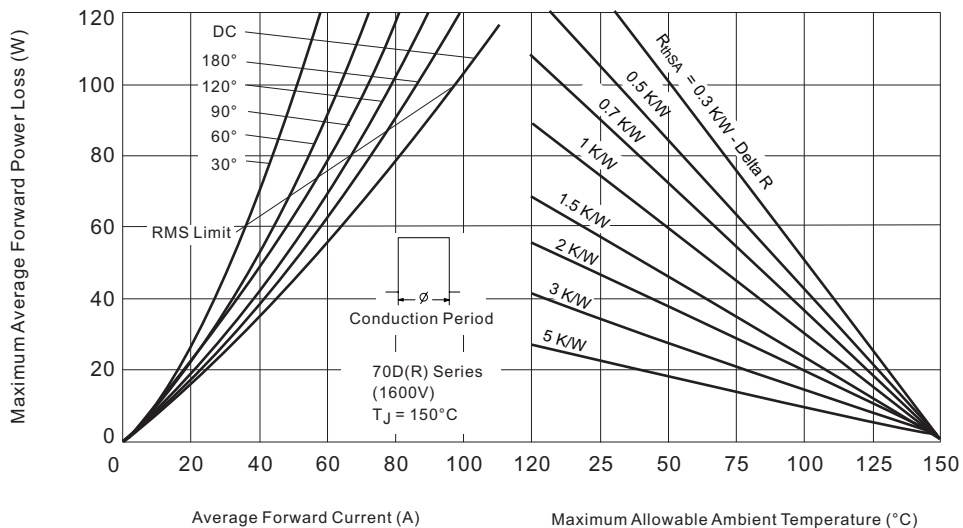

**Fig.10 Maximum Non-Repetitive Surge Current**

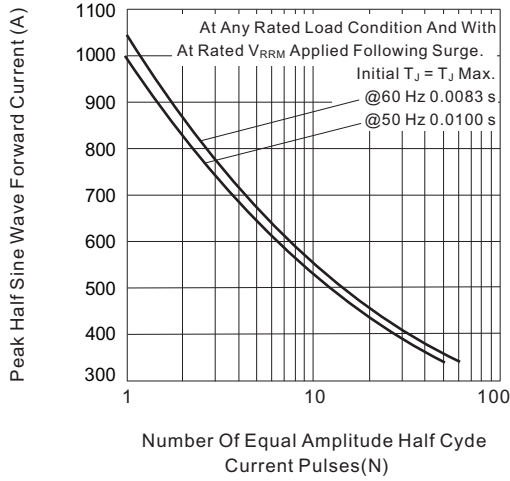

**Fig.10 Forward Voltage Drop Characteristics (Up to 1200V)**

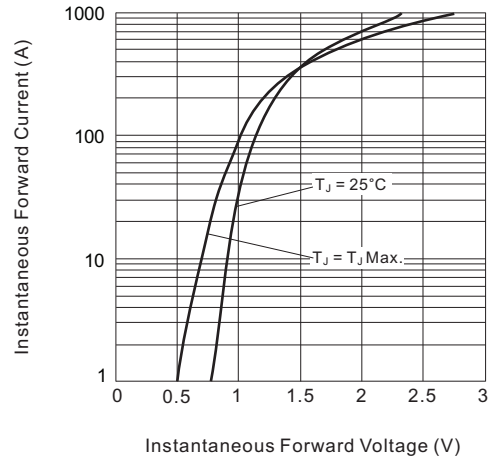

**Fig.11 maximum Non-Repetitive Surge Current**

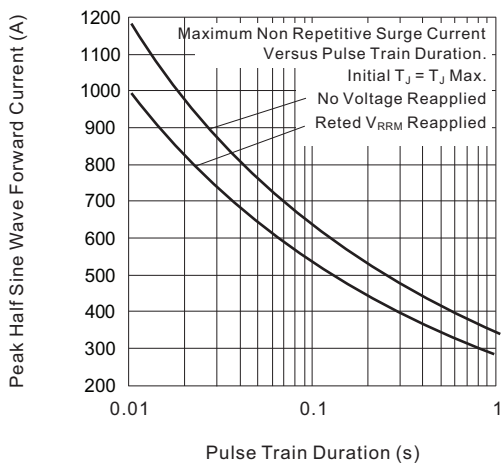

**Fig.12 Thermal Impedance  $Z_{thJC}$  Characteristics**

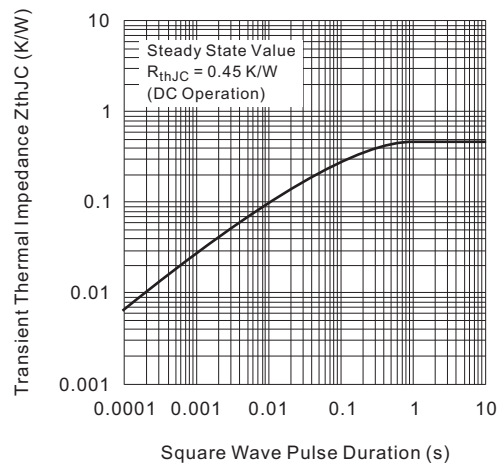

**Fig.13 Forward Voltage Drop Characteristics (For 1600V)**

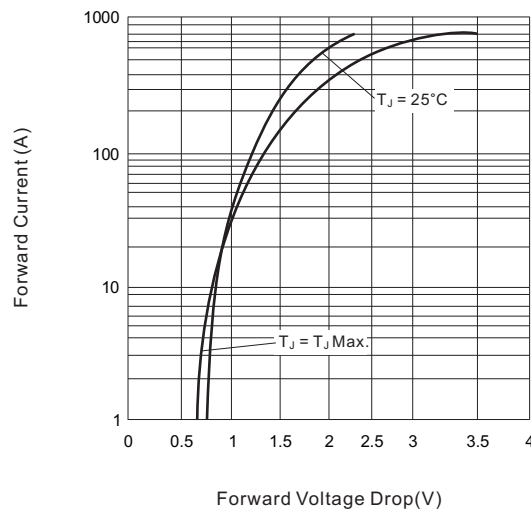

## ORDERING INFORMATION TABLE

Device code	<b>70</b>	<b>D</b>	<b>R</b>	<b>12</b>	<b>M</b>
	①	②	③	④	⑤

- ① - Current rating: Code =  $I_{F(AV)}$
- ② - D = Standard recovery device
- ③ - None = Stud normal polarity (cathode to stud)  
R = Stud reverse polarity (anode to stud)
- ④ - Voltage code  $\times 100 = V_{RRM}$  (see Voltage Ratings table)
- ⑤ - None = Stud base DO-203AB (DO-5) 1/4"-28 UNF-2A, standard type  
M = Stud base DO-203AB (DO-5) M6 $\times$ 1.0, standard type  
S = Stud base DO-203AB (DO-5) M8 $\times$ 1.0, "Semikron" type

### DO-203AB(DO-5), standard type Glass-Metal Seal

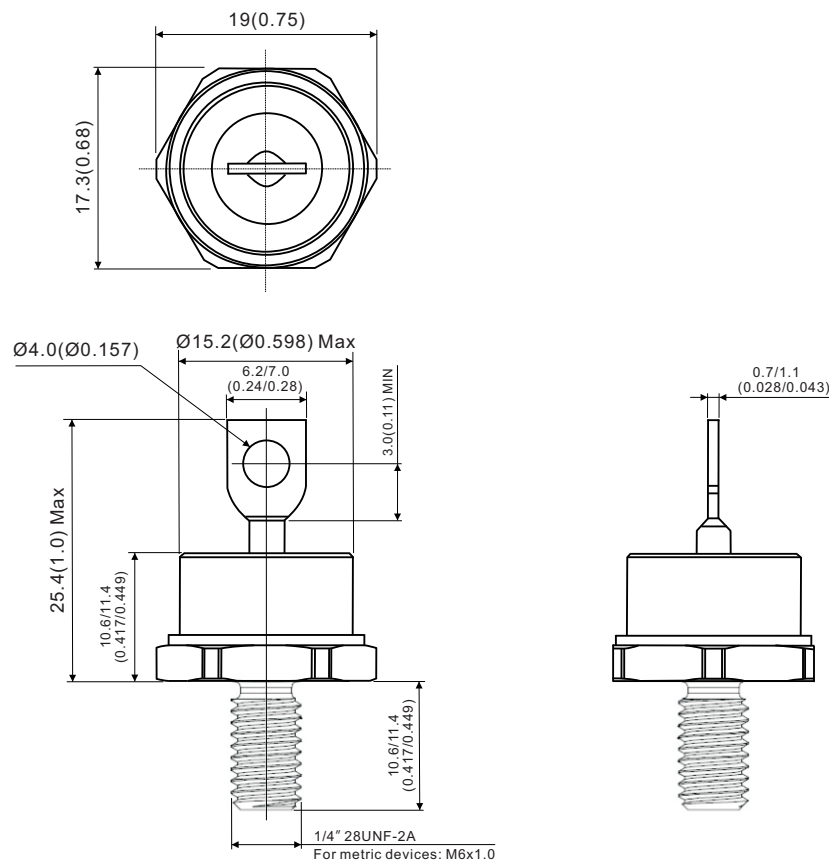

All dimensions in millimeters (inches)

**DO-203AB(DO-5), "Semikron" type  
Glass-Metal Seal**

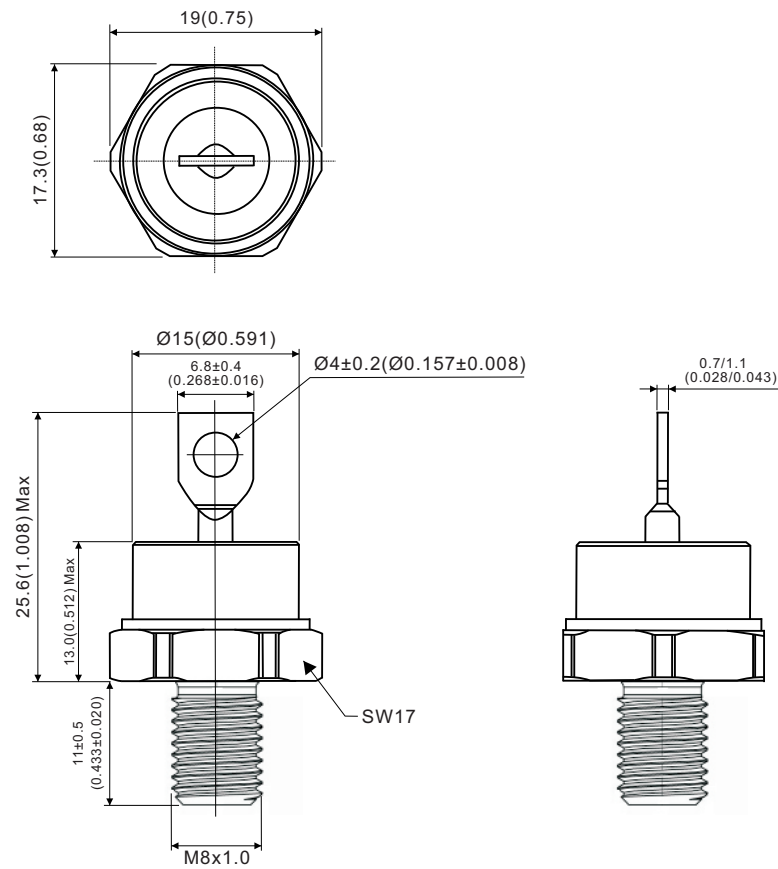

All dimensions in millimeters (inches)