

“*” Pivot Dimension

RoHS Component

PO(X)	A	B	WIRE	CURRENT RATING(A)
1	2.5	4.5	12#	10
2	3.6	5.0	10#	20
3	4.4	5.5	8#	30
4	5.5	5.5	6#	40

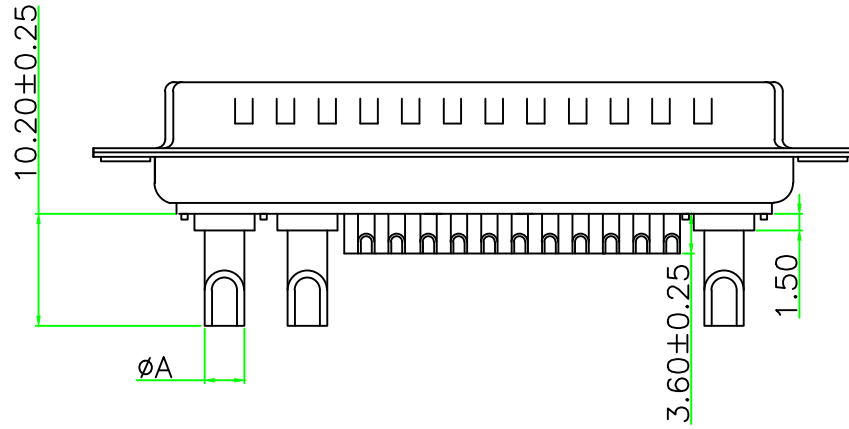
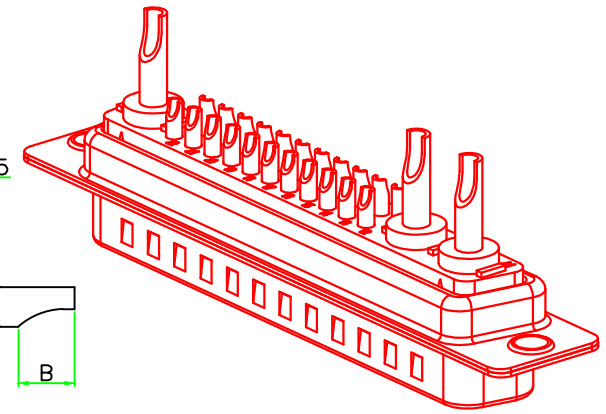
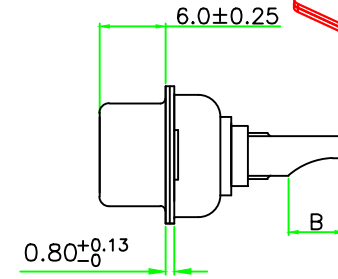
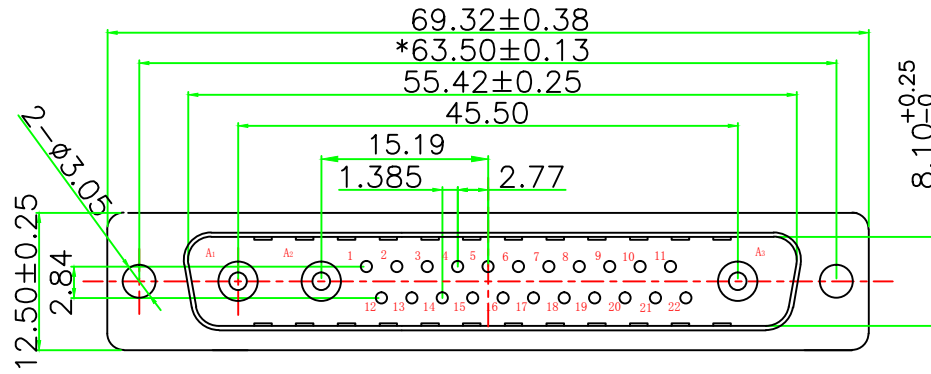

MATERIALS AND FINISH

SHELL:STEEL OR COPPER ALLOY MATERIAL, Tin/Ni OR Au FINISHED.
 CONNECTOR INSULATOR:PBT THERMOPLASTIC, 30% GLASS FILLED, UL 94V-0 RATED.
 HIGH POWER CONTACT :COPPER ALLOY MATERIAL, GOLD PLATED.
 CONNECTOR WITH SIGNAL CONTACT MATERIAL: COPPER ALLOY , GOLD PLATED.

ELECTRICAL CHARACTERISTICS

HIGH POWER CONTACT CURRENT RATING:10, 20, 30 OR 40 AMPS.
 CONNECTOR WITH SIGNAL CONTACT CURRENT RATING :5.0 AMPS.
 THE WORKING VOLTAGE:300V.
 HIGH POWER CONTACT RESISTANCE:2.7 MILLIOHMS MAX.
 DIELECTRIC WITHSTANDING VOLTAGE:1000 V AC FOR 1 MINUTE.
 INSULATION RESISTANCE:2000 MEGAOHMS MIN.
 TEMPERATURE RATING:-55° ~+125° .

TOLERANCE: X. ±0.38 X.X ±0.25 X.XX ±0.13 X° ±3° X.X° ±1°	DRAWN BY : DATE : 2009.09.11	PART NAME: 25W3 公 电流焊线式传统铆合	
	CHECKED BY: DATE : 2009.09.12	DRAW NO. _____	PART NO. _____
UNIT: mm [inch] SCALE:1:1 SIZE: A4	APPROVED BY: DATE : 2010.01.30	REMARK _____	MOLD NO. _____