

产品规格书

SPECIFICATION FOR APPROVAL

客 户 CUSTOMER _____
样品编号 SPEC NO _____
产品型号 PART NO 5MM 白发紫长脚
客户料号 PART NO _____
产品规格 MODEL 5mm 圆头紫光无色透明
日 期 DATE _____

客户确认结果及意见 CUSTOMER CONFIRMATION OUTCOME OPINION:

客户确认：合格 <input type="checkbox"/> 不合格 <input type="checkbox"/>	年 月 日
客户意见：	

承认签名 APPROVED SIGN-ATURES

核 准 PREPARED BY		核 对 CHECKED BY		承 认 ACCEPT	
--------------------	--	-------------------	--	---------------	--

核 准： 核 对： 填 表：
PREPARED BY: CHECKED BY: APPROVED BY:

尺寸图：

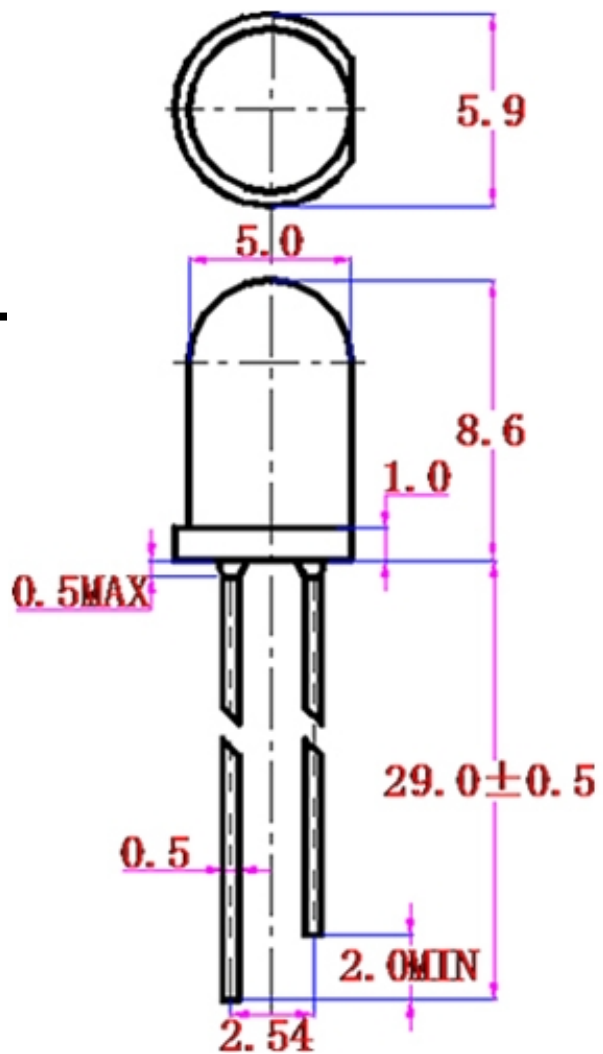

Item	Materials
Resin	Epoxy
Lens Color	Colorless
Lead Frame	Ag plating ironwork Alloy
D	ce AlGaInP

SPECIFICATION

Absolute Maximum Rating ($T_a = 25^\circ\text{C}$)

Items	Symbol	Absolute maximum Rating	Unit
Forward Current	I_F	30	mA
Peak Forward Current *	I_{FP}	100	mA
Reverse Voltage	V_R	5	V
Power Dissipation	P_D	120	mW
Electrostatic discharge	ESD	2000	V
Operation Temperature	T_{opr}	-30 ~ +85	°C
Storage Temperature	T_{stg}	-40 ~ +100	°C
Lead Soldering Temperature *	T_{sol}	Max 260°C for 5 sec Max	

* I_{FP} Conditions: Pulse Width ≤ 10 msec

* T_{sol} Conditions: 3mm from the base of the epoxy bulb

Initial Electrical/Optical Characteristics (Ta=25°C)

项目	符号	条件值	Min.	Typ.	Max.	Unit
顺向电压	V_F	$I_F = 20$ mA	3.0	---	4.0	V
反向电流	I_R	$V_R = 5$ V	---	---	10	μ A
波长	λ_d	$I_F = 20$ mA	390	----	400	nm
亮度	I_v	$I_F = 20$ mA	150	-----	300	mcd
视角	$2\theta_{1/2}$	$I_F = 20$ mA	---	20	---	deg

Notes:

*One normal delivery will include all ranks listed above.

The quantity ratio of the ranks is decided by LaiSuo

Measurement Uncertainty of the Luminous intensity : $\pm 15\%$

Measurement Uncertainty of the Dominant Wavelength : ± 1.0 nm

RELIABILITY

Test Items And Results

Type	Test Item	REF. Standard	Test Condition	Note	Number of Damaged
Environmental Sequence	Temperature Cycle	JIS C 7021 (1977)A-4	-40°C ⇒ 25°C ⇒ 100°C ⇒ 25°C 30mins, 5mins, 30mins, 5mins	100 cycles	0 / 100
	Thermal Shock	MIL-STD-107D	-40°C ⇒ 100°C 15mins, 15mins	100 cycles	0 / 100
	High Humidity Heat Cycle	JIS C 7021 (1977)A-5	30°C ⇒ 65°C 90%RH 24hrs/1cycle	10 cycles	0 / 100
	High Temperature Storage	JIS C 7021 (1977)B-10	T _a = 100°C	1000hrs	0 / 100
	Humidity Heat Storage	JIS C 7021 (1977)B-11	T _a = 60°C RH = 90%	1000hrs	0 / 100
	Low Temperature Storage	JIS C 7021 (1977)B-12	T _a = -40°C	1000hrs	0 / 100
Operation Sequence	Life Test	JIS C 7035 (1985)	T _a = 25°C I _F = 30mA	1000hrs	0 / 100
	High Humidity Heat Life Test	*	60°C RH=90% I _F = 20mA	500hrs	0 / 100
	Low Temperature Life Test	*	T _a = -40°C I _F = 20mA	1000hrs	0 / 100
Destructive Sequence	Resistance to Soldering Heat	JIS C 7021 (1977)A-11	T _{sol} = 260±5°C , 10sec (3mm from the base of the epoxy bulb)	1 time	0 / 20
	Solderability	JIS C 7021 (1977)A-2	T _{sol} = 235±5°C , 5sec (using flux)	1 time (over 95%)	0 / 20
	Lead Pull/Bend Test	JIS C 7021 (1977)A-11	Load 2.5N (0.25kgf) 0° ⇒ 90° ⇒ 0° bend 3 times	No noticeable damage	0 / 20

*Refer to reliability test standard specification for in this line.

紫光是可见光中波长最短的，是可见光中透射度最强的，也是对生物体危害最大的光。紫光 led 的波长是 400nm，频率为 7.5×10^{14} Hz。它在显示生物体秘密的同时，又对生物有着强烈的破坏作用。它是病毒研究中必用的光，又是可将病毒致死的光。紫光将伴着生物界，伴着人类的文明，在地球上永远播散着它那美丽而神奇的光波。

紫光 LED 主要应用领域：

- 1: UV 胶水固化、油墨固化；
- 2: 钞票鉴定（人民币、美金、港币、欧元、英镑）；
- 3: 空调及汽车循环系统的检漏检查；
- 4: 特种气体、油气管道的渗漏检查；
- 5: 公安系统验痕、血迹，作案现场的检查；
- 6: 猎奇寻宝、寻矿野外探索工具；
- 7: 古董鉴定；
- 8: 特殊物质的荧光反射。

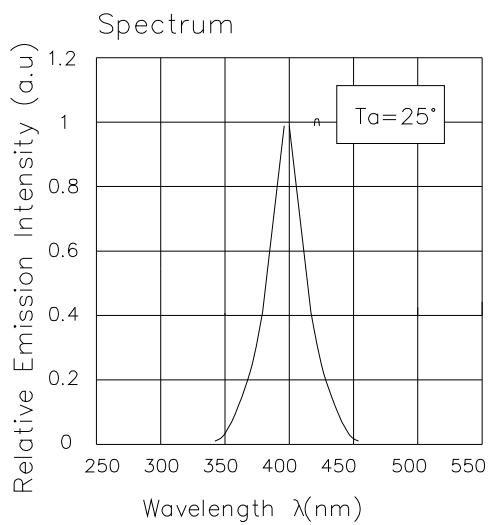
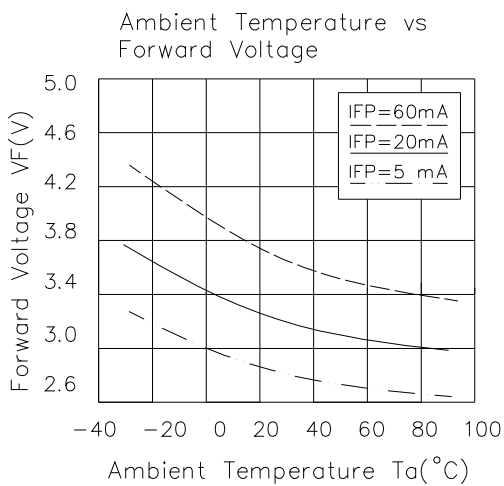
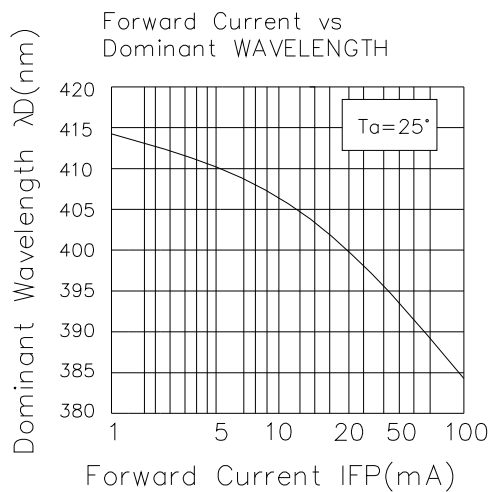
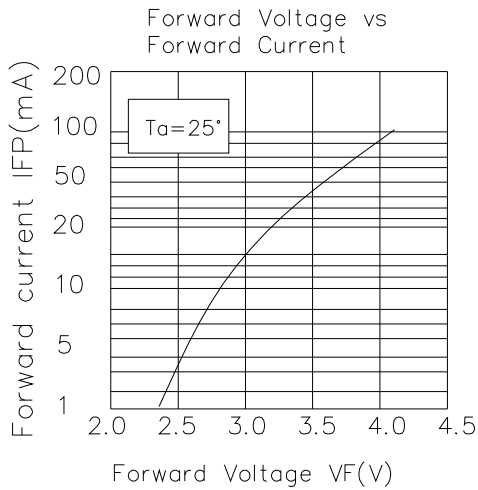

A)