

“*” Pivot Dimension

RoHS Component

PO(X)	A	B	WIRE	CURRENT RATING (A)
1	2.5	4.5	12#	10
2	3.6	5.0	10#	20
3	4.4	5.5	8#	30
4	5.5	5.5	6#	40

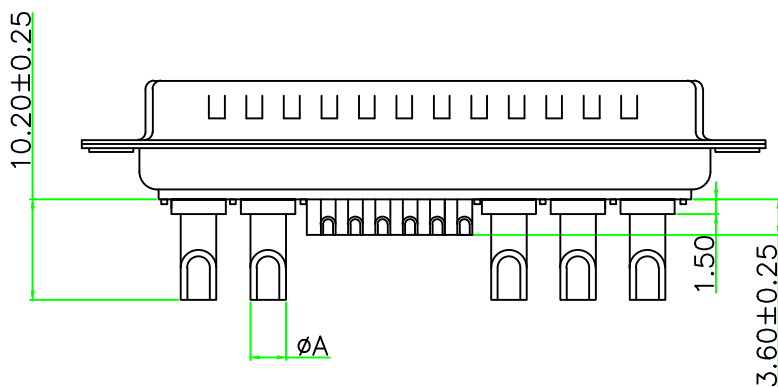
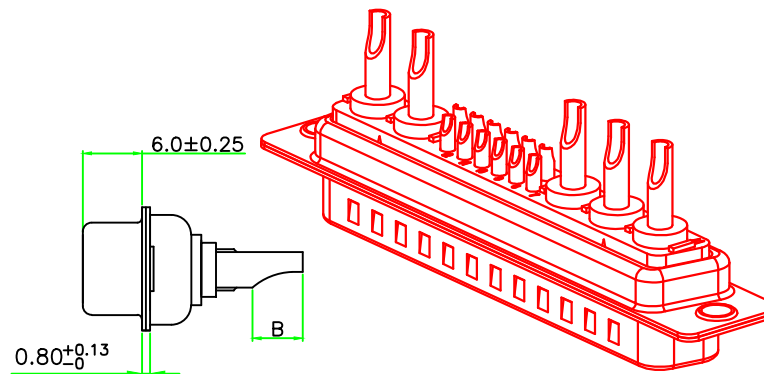
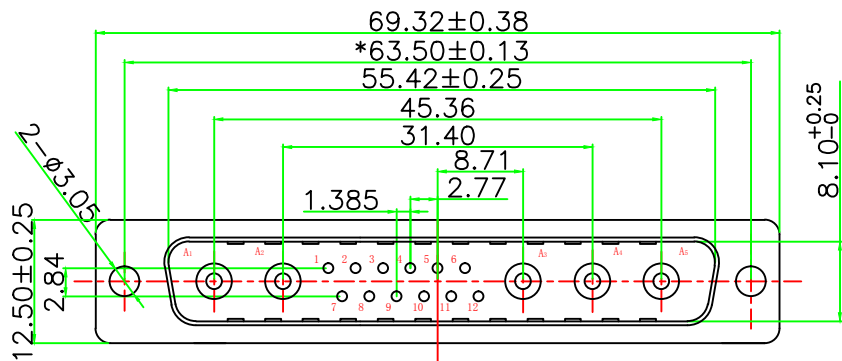

MATERIALS AND FINISH

SHELL: STEEL OR COPPER ALLOY MATERIAL, Tin/Ni OR Au FINISHED.
 CONNECTOR INSULATOR: PBT THERMOPLASTIC, 30% GLASS FILLED, UL 94V-0 RATED.
 HIGH POWER CONTACT : COPPER ALLOY MATERIAL, GOLD PLATED.
 CONNECTOR WITH SIGNAL CONTACT MATERIAL: COPPER ALLOY , GOLD PLATED.
ELECTRICAL CHARACTERISTICS
 HIGH POWER CONTACT CURRENT RATING: 10, 20, 30 OR 40 AMPS.
 CONNECTOR WITH SIGNAL CONTACT CURRENT RATING : 5.0 AMPS.
 THE WORKING VOLTAGE: 300V.
 HIGH POWER CONTACT RESISTANCE: 2.7 MILLIOHMS MAX.
 DIELECTRIC WITHSTANDING VOLTAGE: 1000 V AC FOR 1 MINUTE.
 INSULATION RESISTANCE: 2000 MEGAOHMS MIN.
 TEMPERATURE RATING: -55° ~ +125° .

TOLERANCE: X. ±0.38 XX ±0.25 XXX ±0.13 X.* ±3° X.* ±1°		DRAWN BY :	DATE : 2009.09.11	PART NAME: 17W5 母 电流焊线式传统铆合	
 UNIT: mm [inch] SCALE: 1:1 SIZE: A4		CHECKED BY :	DATE : 2009.09.12	DRAW NO.	
		APPROVED BY :	DATE : 2010.01.30	PART NO.	
				REMARK	
				MOLD NO.	